

AMP-SOL-2 Series Solenoid Amplifier Users' Manual

Servo Tech Inc

1747 W. Roosevelt Rd, Suite 110
Chicago, IL 60608

Ph: (312) 997-3733 Fax: (312) 997-3734
www.ServoTechInc.com

TABLE OF CONTENTS

- 1. The AMP-SOL-2 Series Solenoid Amplifier.....3
 - 1.1. Components of the Package.....3
 - 1.2. Technical Specifications.....4
 - 1.3. Hardware Requirements.....5
 - 1.4. Connection Ports and Cables.....6

- 2. Installing Your AMP-SOL-2.....8
 - 2.1. How Does It Work.....8
 - 2.2. How to Wire and Use it.....12

- 3. Contact Information.....13

1. The AMP-SOL-2 Series Solenoid Amplifier

The AMP-SOL-2 Series Solenoid Driver board drives two proportional solenoids. The board accepts digital pulse width modulated (PWM) input (0 –5V) or analog voltage (0-5V or 0-10V) as current command signals. The output current is controlled by means of a switching technique (25 kHz steady-state) allowing efficient operation. Each channel can provide up to 2A of regulated current regardless of coil resistance. It accepts power supply voltages from 12V to 26V. An “OK/Fault” output signal alerts the user of short-circuit or open-circuit condition at the load. Load short-circuit and open-circuit protection circuit disables the output and the driver becomes functional only when power is recycled. Reverse polarity detection circuit disables the power output stage when it detects reverse voltage polarity, but it does not change the state of “OK/Fault” signal. The current through the solenoid can be monitored as an analog signal in the 0-10V range.

Features:

- Supply voltage range: 12V –26V.
- Two channel output
- Up to 2A/channel current capacity
- Proportional output current control
- Output current is regulated with current loop feedback
- High frequency switching output (25 kHz)
- Accepts both PWM (0V low, 5V high) and analog inputs (0-5V range, or 0-10 V range) as current command. Jumper selected.
- Load short-circuit shut-down
- OK/Fault flag to indicate load short-circuit or open-circuit
- Reverse polarity protected by turning OFF power output stage.

1.1. Components of the Package

1. AMP-SOL-2 Board (with two jumpers on JP3 and JP4 installed in default positions)
2. Users’ Manual

1.2. Technical Specifications

Input Specifications	
Power Supply	12-26 VDC
Current command (Input) Signal for each one of two channels:	PWM1 and PWM2: 0-100%, 2 kHz to 20 kHz range, Non-isolated, Low <0.8 V, High 5V, TTL and CMOS compatible Or Analog 1 and Analog 2: Analog voltage 0 V to 5 V Or Analog voltage 0 V to 10 V
Output Specifications	
Maximum output current per channel	2 A per Channel
PWM Output: PWM1, PWM2	25 kHz switching frequency under steady state.
OK/Fault (Load Short-Circuit/Open Circuit) OK/Fault 1 , OK/Fault 2	Fault: Low No Fault: High
Current monitor output: Current Monitor 1, Current Monitor 2	0V-10V range corresponding to 0A to 2A current output
General Specifications	
Short Circuit protection	YES
Open Circuit protection	YES
Reverse Polarity protection	YES
Electrical Connection	Screw terminals, 12 - 16 AWG wire
Mechanical Dimensions	4.0" X 3.55"
Operating Temperature Range	-40 C to 85 C

1.3. Hardware Requirements

1. Power Supply: 12 V to 26 V
2. Current Command Signal: PWM (0-5V, 2 kHz-20 kHz, 0-100% duty cycle) or Analog Source (0V to 5V or 0V to 10V).
3. Analog Signal Source 5V for Enable1/Enable2 signals.

1.4. Connection Ports and Cables

Connector JP1

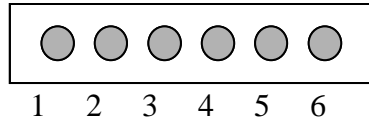

Connector#	Name
1	Input Voltage (12V – 26V)
2	Power Ground
3	Solenoid#1 High
4	Solenoid#1 Low
5	Solenoid#2 High
6	Solenoid#2 Low

Connector JP2

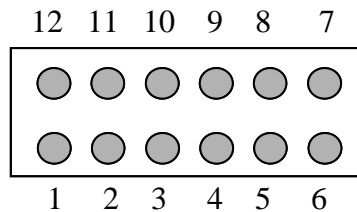

Connector#	Name	Description
1	Analog Current Command 1	Commands the current in Solenoid#1
2	PWM Current Command 1	Commands the current in Solenoid#1
3	Enable Driver 2	Enables Driver#2 when high
4	PWM Current Command 2	Commands the current in Solenoid#2
5	Enable Driver 1	Enables Driver#1 when high
6	OK/Fault Status 2	Indicates a solenoid#2 open-circuit or Short-circuit fault when low
7	OK/Fault Status 1	Indicates a solenoid#1 open-circuit or Short-circuit fault when low
8	Analog Current Monitor 2	Current in solenoid#2 (0 - 10 V)
9	Analog Current Command 2	Commands current in solenoid#2
10	Ground	Ground
11	Analog Current Monitor 1	Current in solenoid#1 (0 - 10 V)
12	Ground	Ground

Connectors: JP3 and JP4

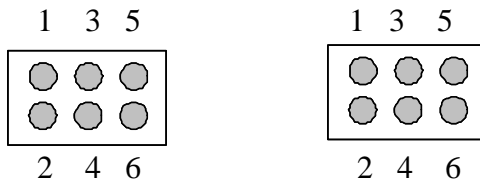

- Shorting pins 1-2 configures solenoid current command as analog 0 to 5 V
- Shorting pins 3-4 configures solenoid current command as analog 0 to 10 V
- Shorting pins 5-6 configures solenoid current command as PWM

2. Installing Your AMP-SOL-2

2.1. How Does It Work

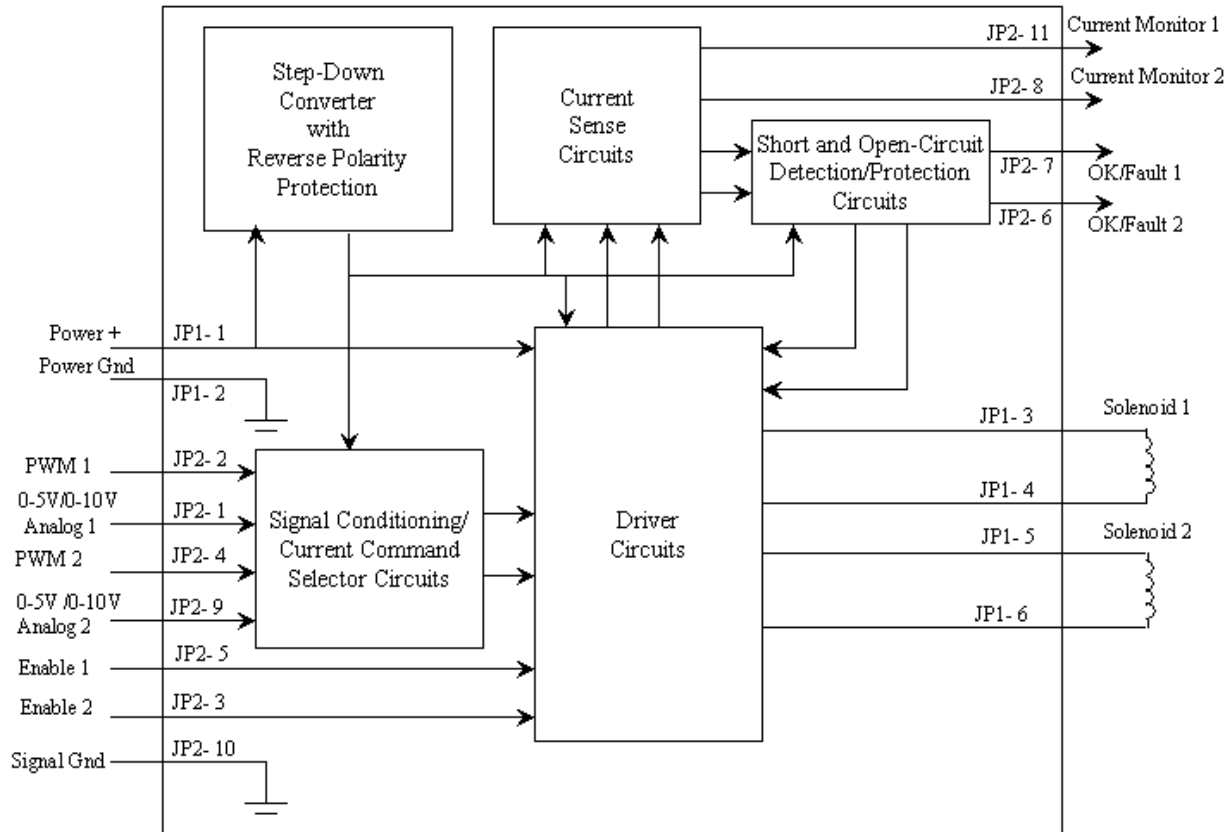

Fig 1: Block Diagram of AMP-SOL-2 Solenoid Driver Board

The AMP-SOL-2 solenoid driver board has two independent solenoid driver channels. The peak current in each channel can be programmed separately through a current command input which is proportional to a digital pulse width modulated input signal or an analog signal. Each channel can be disabled/enabled through an enable input signal. A current sensing circuit maintains the current irrespective of the fluctuations in the input power supply.

Two step-down voltage regulators (LM2937ET-10 and LM2937ET-5.0) generate 10V and 5V required for control circuitry. The voltage regulators are reverse-polarity protected and turn-off when reverse voltage is applied at its input. This in turn disables the driver chip.

By shunting different pins of Headers JP3 and JP4, current command signal can be configured to be a PWM signal, analog signal in 0-5 V range or analog signal in 0-10 V range. The current sense circuit uses a differential amplifier to detect the voltage across the current sense resistor in series with the solenoid. The closed loop current switching logic inside the PWM driver maintains the current in the solenoid equal to the commanded value. Under steady state the output switching frequency is 25 kHz. The current monitor signals indicate the current through the solenoids. A voltage of 10 V at the current monitor output corresponds to 2 A and 0V

corresponds to 0A.

Short-Circuit protection circuit monitors the current through the solenoid and disables the channel, if a short is detected at the load. OK/Fault status signal will go low (high for normal operation). Once the short at the output is removed, recycling power to the board enables the driver. Open-Circuit detection circuit forces the OK/Fault status signal low if an open-circuit is detected at the load.

The Driver block consists of ST Microelectronics solenoid driver chip L295 and associated circuitry. It has two independent driver channels and is controlled by three digital inputs (chip enable (EN), driver#1 enable (V_{EN1}) and driver#2 enable (V_{EN2})) and two analog inputs (current commands to program the solenoid currents, V_{ref1} and V_{ref2}). When driver#1 is activated by low level on EN input and high on V_{EN1} , the output transistors of the driver circuit switch ON and current rises through solenoid#1 (Refer to Fig.2). A current sense circuit within the driver chip senses the current through the solenoid. When the solenoid current equals the current command reference V_{ref1} , the output transistors are switched OFF and the current in the solenoid starts to decay. An internal oscillator fixed at 25 kHz, turns ON the output transistors at its next clock pulse and the current in the solenoid rises again. When the solenoid current reaches V_{ref1} value, the output transistors are again switched OFF. This process is repeated, regulating the solenoid current until V_{EN1} goes low. The operation of driver#2 is same as above.

For detailed information on driver operation, refer to L295 (ST Microelectronics) datasheet.

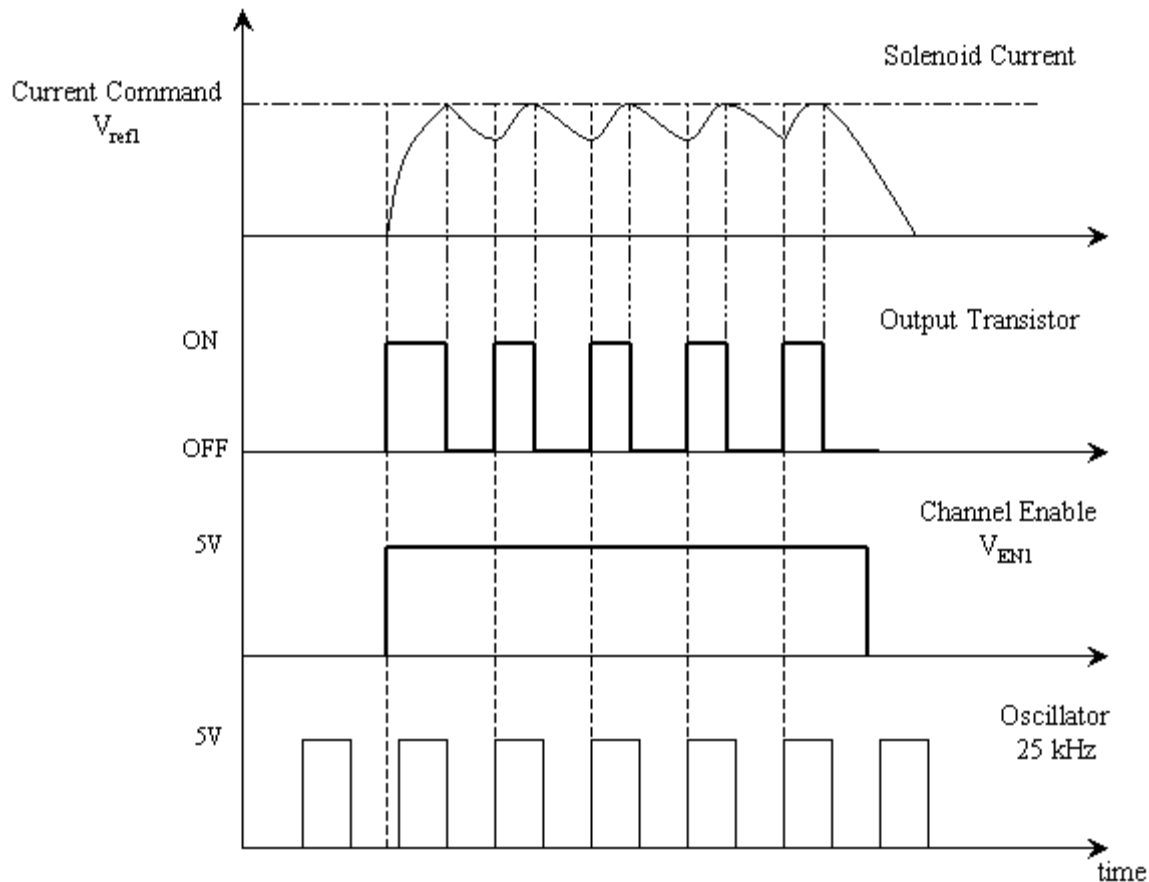

Fig.2 Operation of L295 Driver

Signal Conditioning/Current Command selector block consists of a low pass filter and two headers JP3 and JP4. Current command can be configured as PWM, analog 0-5 V range or analog 0-10 V range, by choosing the jumper (JP3/JP4) configuration.

The PWM current command signal is passed through a second-order Sallen-Key low-pass filter and a resistor voltage divider to generate current command (V_{ref1} and V_{ref2}) in the 0-2 V range. 100% duty-cycle generates a current command of 2 A and 0% duty-cycle generates a current command of 0 A. The analog commands are scaled down using a resistor voltage divider to generate V_{ref1}/V_{ref2} in the 0-2 V range. An analog input voltage of 5V/10V corresponds to 2 A and 0V corresponds to a current command of 0 A.

A current-sense circuit senses the voltage across a current sense resistor in series with the solenoid and amplifies it to 0-10 V range. A voltage of 10 V at the current monitor output corresponds to 2 A and 0V corresponds to 0A.

Load Short-circuit protection block monitors the current through the solenoid and sets a D flip-flop if the current increases above 2.4 A. The D flip-flop disables the driver by making V_{EN1}/V_{EN2} low. OK/status flag goes low. Recycling power to the board resets the D flip-flop.

Load Open-circuit detection circuit monitors the current through the solenoid and if it is below 0.06 A when the driver is enabled and the current command V_{ref1}/V_{ref2} is above 0.15 A, OK/Fault status signal goes low.

2.2. How to Wire and Use It

Refer to Fig.1 for wiring details.

1. To use PWM input as current command for Driver#1, install jumper on pins 5 and 6 of header JP3 (Pins 5 and 6 of header JP4 for Driver#2). The remaining pins of the header should be left open.
2. Connect PWM source to pin 2 and its ground to pin 10 (or 12) of header JP2, if Driver#1 is configured as in step 1. (For Driver#2, use pins 4 and 10 (or 12) of JP2 for PWM source and ground respectively).
3. To use 0-5V analog voltage as current command input for Driver#1, install jumper on pins 1 and 2 of header JP3 (Pins 1 and 2 of header JP4 for Driver#2). The remaining pins of the header should be left open.
4. Connect 0-5V analog source to pin 1 and its ground to pin 10 (or 12) of header JP2, if Driver#1 is configured as in step 3. (For Driver#2, use pins 9 and 10(or 12) of JP2 for input source and ground respectively).
5. To use 0-10V analog voltage as current command input for Driver#1, install jumper on pins 3 and 4 of header JP3 (Pins 3 and 4 of header JP4 for Driver#2). The remaining pins of the header should be left open.
6. Connect 0-10 V analog source to pin 1 and its ground to pin 10 (or 12) of header JP2, if Driver#1 is configured as in step 5. (For Driver#2, use pins 9 and 10(or 12) of JP2 for input source and ground respectively).
7. Connect input power supply (12-26V) between pins 1 and 2 of header JP1.
8. Connect a proportional solenoid between pins 3 and 4 of JP1 to use Driver#1 (Pins 5 and 6 of JP2 to use Driver#2).
9. To enable Driver#1, connect 5V to pin 5 of JP2 (Pin 3 of JP2 to enable Driver#2).

3. CONTACT INFORMATION

For any questions, please contact us.

Address: Servo Tech Inc
1747 W. Roosevelt Rd, Suite 110
Chicago, IL, 60608

Phone: (312) 997-3733

Fax: (312) 997-3734

Web: www.ServoTechInc.com